

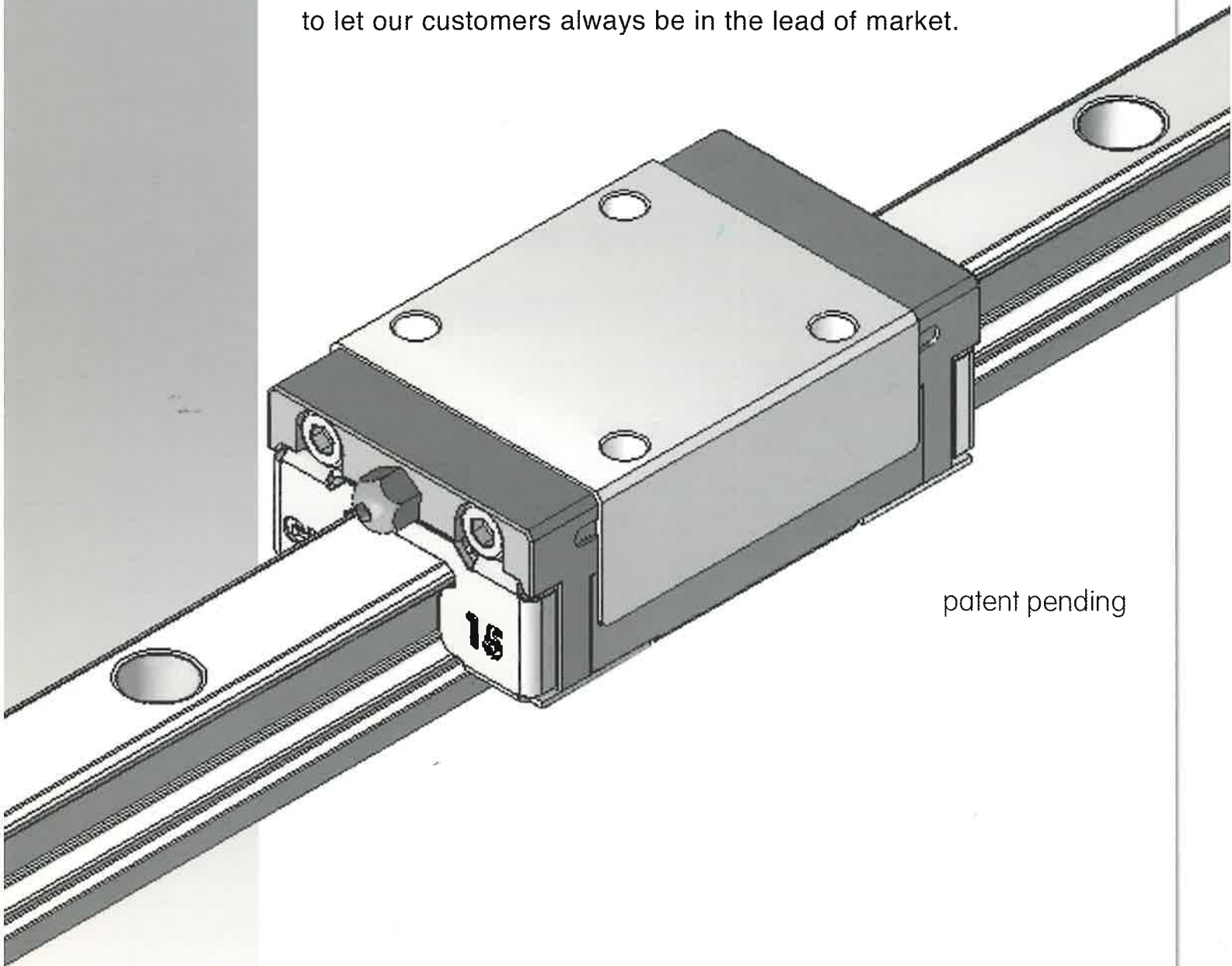

# CHIEFTECH PRECISION CO., LTD.

## **cpc**

provides only the best quality and the greatest creativity products to let our customers always be in the lead of market.



patent pending

## Ball Type Linear Guide Series

CPC ball type linear guide series has 4 rows of balls in 2 point contact design which guarantees the friction to a minimum, and the 45 degree contact angle arrangement of balls provides an equal load ratings vertically and laterally. The utilization of larger size of balls in O-type arrangement increase the load and moment capacity, and also the rigidity.

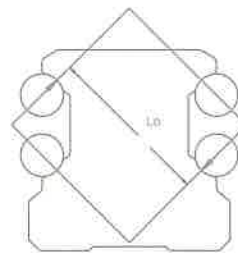

O Type - Arrangement

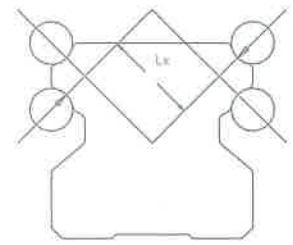

X Type - Arrangement

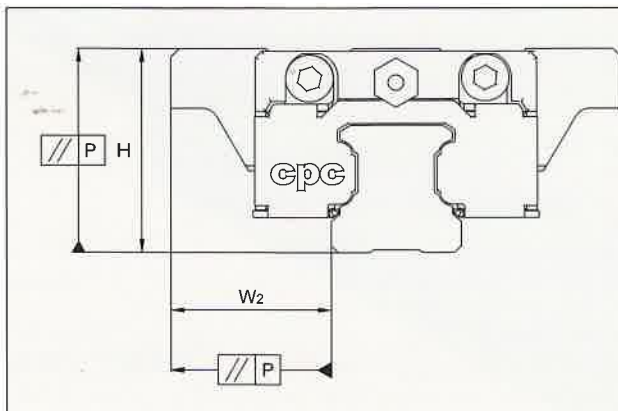
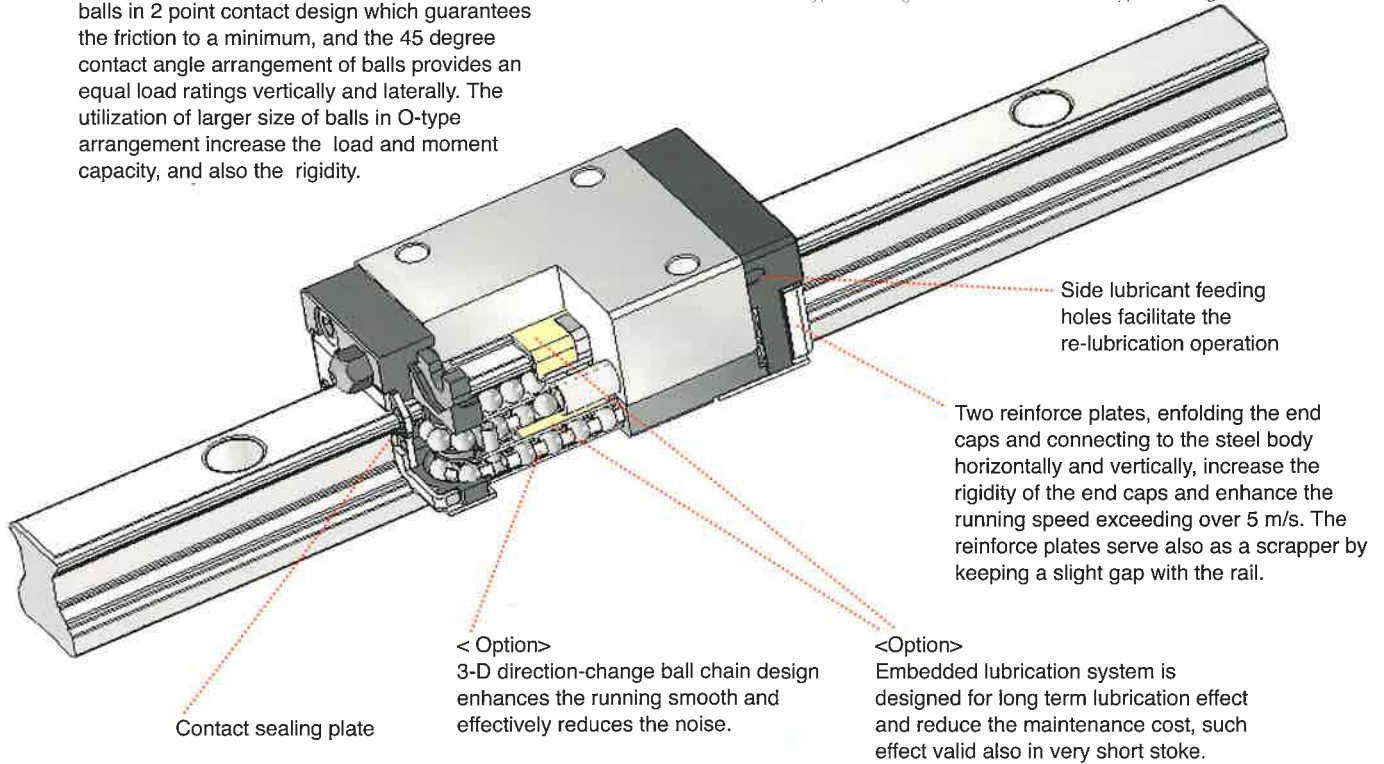

Table of Accuracy

Accuracy Classes ( $\mu\text{m}$ )		Ultra Precision UP	Super Precision SP	Precision P	High H	Normal N
Tolerance of dimension height H	H	$\pm 5$	$\pm 10$	$\pm 20$	$\pm 40$	$\pm 100$
Variation of height for different runner block on the same position of rail	$\Delta H$	3	5	7	15	30
Tolerance of dimension width $W_2$	$W_2$	$\pm 5$	$\pm 7$	$\pm 10$	$\pm 20$	$\pm 40$
Variation of width for different runner block on same position of rail	$\Delta W_2$	3	5	7	15	30

Accuracy of the running parallelism

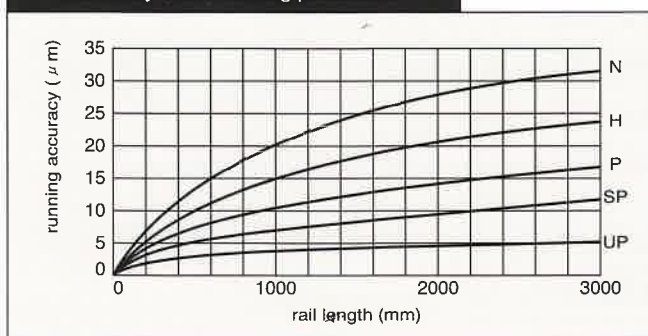
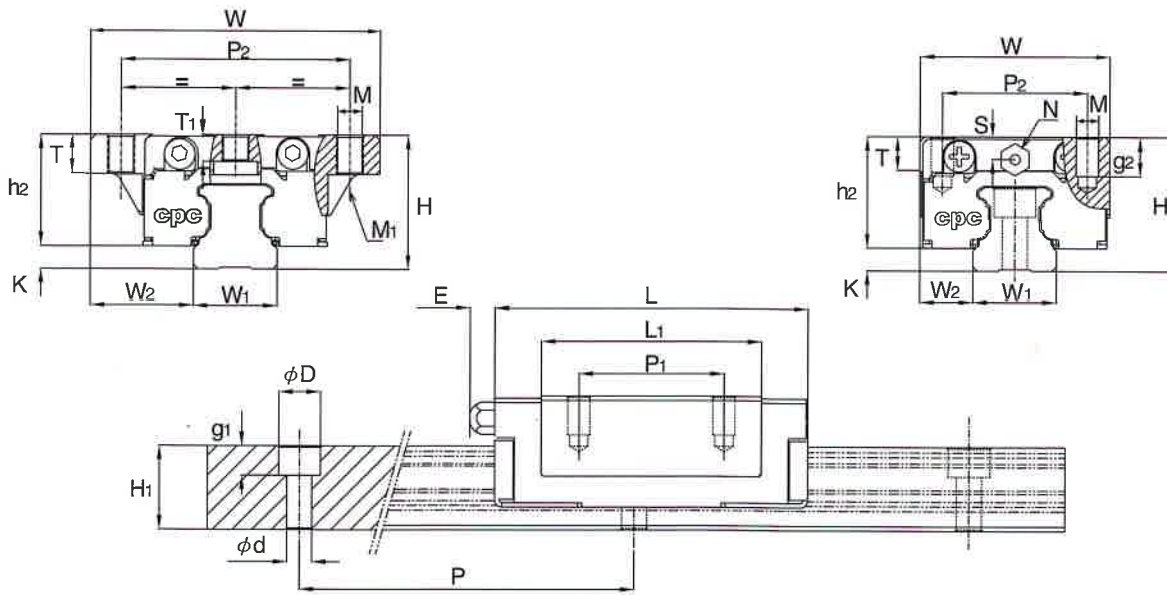

Table of Preload

Preload Classes	V0	V1	V2	V3
<b>AR</b> Small clearance to light preload		0.02C	0.05C	0.08C
<b>HR</b> Small clearance to light preload		0.02C	0.08C	0.13C



## AR Automation Series

Unit : mm

Size	Assembly Dimensions		Rail Dimensions (mm)					Block Dimensions (mm)											Load Capacity (KN)		Static Moment (KNm)		
	H	W <sub>2</sub>	W <sub>1</sub>	H <sub>1</sub>	P	D × d × g <sub>1</sub>	W	L	L <sub>1</sub>	h <sub>2</sub>	P <sub>1</sub>	P <sub>2</sub>	E	M × g <sub>2</sub>	M <sub>1</sub>	S	T	T <sub>1</sub>	C	C <sub>0</sub>	M <sub>r0</sub>	M <sub>p0</sub>	M <sub>y0</sub>
AR 15MS	24	9.5	15	15	60	7.5x4.5x5.3 (6x3.5x4.5)	34	41	24.2	20	-	26	4.5	M4x7		4.2	6		6.4	10.8	0.08	0.04	0.04
AR 15MN	24	9.5	15	15	60		34	56.3	39.5	20	26	26	4.5	M4x7		4.2	6		9.0	17.5	0.14	0.1	0.1
AR 15FS	24	18.5	15	15	60		52	41	24.2	20	-	41	4.5	M5x6	M4	4.2	6		6.4	10.8	0.08	0.04	0.04
AR 15FN	24	18.5	15	15	60		52	56.3	39.5	20	26	41	4.5	M5x6	M4	4.2	6		9.0	17.5	0.14	0.1	0.1
AR 20MS	28	11	20	20.3	60	9.5x6x8.5	42	48	30	22	-	32	12	M5x7		6	7		10.9	16.3	0.17	0.08	0.08
AR 20MN	28	11	20	20.3	60		42	70	52	22	32	32	12	M5x7		6	7		15.6	29.8	0.31	0.22	0.22
AR 20FS	28	19.5	20	20.3	60		59	48	30	22	-	49	12	M6x9	M5	6	9		10.9	16.3	0.17	0.08	0.08
AR 20FN	28	19.5	20	20.3	60		59	70	52	22	32	49	12	M6x9	M5	6	9		15.6	29.8	0.31	0.22	0.22
AR 25MS	33	12.5	23	24	60	11x7x9	48	60	37	26	-	35	12	M6x9		7	8		12.3	21.2	0.22	0.11	0.11
AR 25MN	33	12.5	23	24	60		48	83	60	26	35	35	12	M6x9		7	8		18.8	36.4	0.41	0.3	0.3
AR 25FS	33	25	23	24	60		73	60	37	26	-	60	12	M8x9	M6	7	10		12.3	21.2	0.22	0.11	0.11
AR 25FN	33	25	23	24	60		73	83	60	26	35	60	12	M8x9	M6	7	10		18.8	36.4	0.41	0.3	0.3

## HR Heavy Load Series

Unit : mm

Size	Assembly Dimensions		Rail Dimensions (mm)					Block Dimensions (mm)											Load Capacity (KN)		Static Moment (KNm)		
	H	W <sub>2</sub>	W <sub>1</sub>	H <sub>1</sub>	P	D × d × g <sub>1</sub>	W	L	L <sub>1</sub>	h <sub>2</sub>	P <sub>1</sub>	P <sub>2</sub>	E	M × g <sub>2</sub>	M <sub>1</sub>	S	T	T <sub>1</sub>	C	C <sub>0</sub>	M <sub>r0</sub>	M <sub>p0</sub>	M <sub>y0</sub>
HR 15MN	28	9.5	15	15	60	7.5x4.5x5.3 (6x3.5x4.5)	34	56.3	39.5	20	26	26	5.5	M4x7		4.2	6		9.0	17.5	0.14	0.1	0.1
HR 15FN	24	16	15	15	60		47	56.3	39.5	20.5	30	38	5.5	M5x9		4.5	7		9.0	17.5	0.14	0.1	0.1
HR 20MN	30	12	20	20.3	60	9.5x6x8.5	44	70	52	26	36	32	12	M5x8.5		5	7		15.6	29.8	0.31	0.22	0.22
HR 20ML	30	12	20	20.3	60		44	90	72	26	50	32	12	M5x8.5		5	7		20.8	43.3	0.43	0.42	0.42
HR 20FN	30	21.5	20	20.3	60		63	70	52	26	40	53	12	M6x9	M5	5	9	4.3	15.6	29.8	0.31	0.22	0.22
HR 20FL	30	21.5	20	20.3	60		63	90	72	26	40	53	12	M6x9	M5	5	9	4.3	20.8	43.3	0.43	0.42	0.42
HR 25MN	40	12.5	23	24	60	11x7x9	48	83	60	34.5	35	35	12	M6x9		10	8		18.8	36.4	0.41	0.3	0.3
HR 25ML	40	12.5	23	24	60		48	103	80	34.5	50	35	12	M6x9		10	8		23.4	48.5	0.56	0.52	0.52
HR 25FN	36	23.5	23	24	60		70	83	60	30.5	45	57	12	M8x9	M6	6	10	5.5	18.8	36.4	0.41	0.3	0.3
HR 25FL	36	23.5	23	24	60		70	103	80	30.5	45	57	12	M8x9	M6	6	10	5.5	23.4	48.5	0.56	0.52	0.52

The above AR and HR rated load capacities are calculated according Din636 Part 2, in which the standard of rated life is 100km travel distance. When the standard of 50km travel distance is used, the above listed rated dynamic load capacity C shall be modified by multiplying 1.26.

Model Number												
AR(U)	E	15	M	N	B2	Z	V1	P	-1480L	-20	-20	II
											No. of rail on the same moving axis	
											Starting hole pitch (mm)	
											End hole pitch (mm)	
											Rail Length (mm)	
											Accuracy classes : UP, SP, P, H, N, grade	
											Preload Classes : V0 : Without preload V1 : Light preload	
											V2 : Middle preload V3 : Heavy preload	
											Z : Equipped with embedded lubrication system	
											Quantity of the runner block	
											Block Length : L : Long N : Normal S : Short	
											Block Type : M : standard F : Wide	
											Rail Type : Such as 15, 20, 25	
											C : Equipped with ball chain E : Size 15 rail mounting hole (6x3.5x4.5)	
Product type : AR : Automation HR : Heavy Load ARU : Automation Upward Screwing HRU : Heavy Load Upward Screwing												

**cpc** CHIEFTECH PRECISION Co., LTD.

No. 3, Dali 1<sup>st</sup> Rd., Sinshih Hsiang,  
 Southern Taiwan Science Park,  
 741-45, Tainan Taiwan  
 TEL:+886-6-5055858  
 FAX:+886-6-5055959  
<http://www.chieftek.com>  
 e-mail:service@mail.chieftek.com  
 Printed Date: April. 2006